

Flow to 160 GPM
Head to 100 ft.

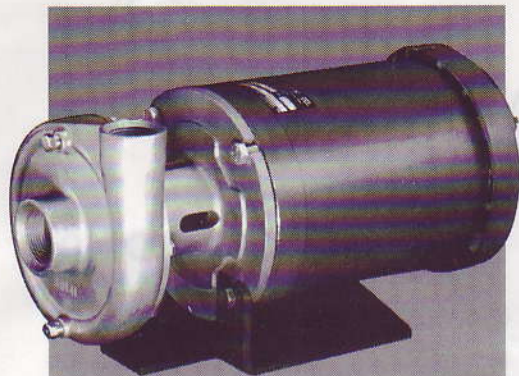

CD100-SS

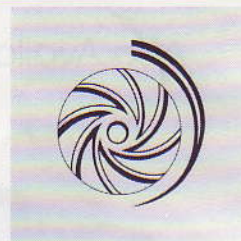

CD100-MD
(Mag Drive)

PRICE PUMP CO.

21775 Eighth St. East
P.O. Box Q
Sonoma, CA 95476
(707) 938-8441
FAX: (707) 938-0764
www.pricepump.com
email: sales@pricepump.com

Type CD, CD-MD

CENTRIFUGAL MOTOR PUMPS

Flows to 160 GPM
Heads to 100 ft.

SIZES

CD100 - 1" x 1 1/4" x 5"
CD150 - 1 1/2" x 2" x 5"

MATERIALS

CD-SS 316 SS
CD-AI All Iron
CD-AB All Bronze

FEATURES

Mechanical Sealed Pumps

- Compact close coupled design using standard NEMA "C" motors
- Back pull-out design for easy maintenance
- **316SS** - John Crane Type 21 Fluoroelastomer, Carbon vs. Ceramic, standard seal
- **Iron or Bronze** - John Crane Type 6A, Buna, Carbon vs. Ceramic, standard seal
- Double Type 21 Seal option
- John Crane Type 9 PTFE seal available on both models
- Optional seal face materials and elastomers include silicon carbide, tungsten carbide, F31 carbon, EPR, Neoprene. (additional materials available)
- Seal flush and seal quench optional

CD-MD (MAG DRIVE)

- Optional temperature and vibration monitoring
- Optional hard coated shaft
- Number of magnets can be varied to match HP requirements
- Optional external flush
- Wide range of bearing materials available
- 56C motors standard

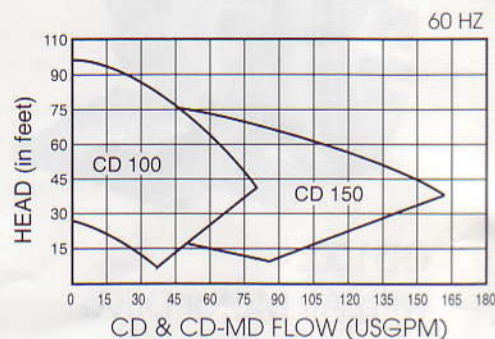

Curve for reference only. See engineering curves for final selection.

Type CD

(For Mag Drive dimensions see reverse)

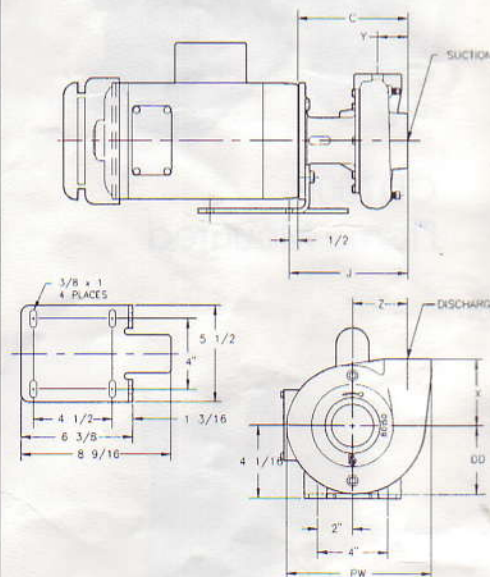

SEE REVERSE FOR MAG DRIVE DIMENSIONS

	PUMP END DIMENSIONS						PIPE THREADS IN INCH		
	C	DD	PW	X	Y	Z	J	SUCTION	DISCHARGE
CD100 SS	5 3/4 146mm	3 1/8 79mm	6 5/8 178mm	3 1/2 89mm	1 3/8 35mm	2 3/4 70mm	6 1/4 210mm	1 1/4" NPT	1" NPT
CD150 SS	6 13/16 173mm	4 1/16 103mm	7 15/16 202mm	3 13/16 97mm	2 1/8 54mm	3 1/16 78mm	7 5/16 196mm	2" NPT	1 1/2" NPT

Flow to 160 GPM
Head to 100 ft.

Also Available:

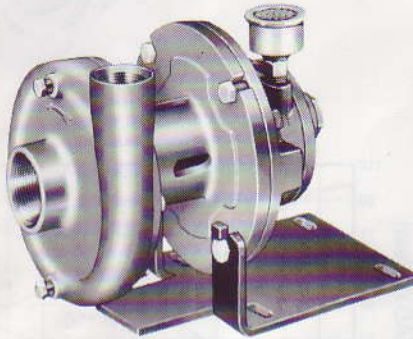

CD100
with Air Motor Drive

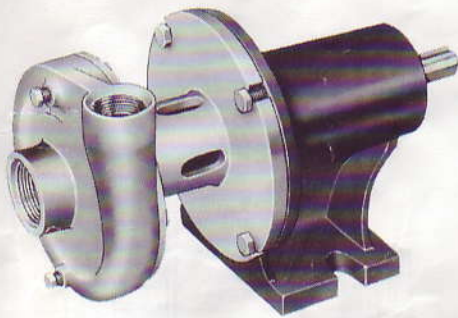

CD100P
Frame Mounted



CD100V
Vertical

Type CD & CD-MD



TECHNICAL INFORMATION

CATEGORY

	CD100	CD150
Minimum Recommended Flow*	12 GPM	25 GPM
Max. Working Pressure (CD100SS/CD100AI)**	150/75 PSIG	150/75 PSIG
Max. Temperature (CD-SS/CD-AI)**	250°F	250°F
Maximum Solid Size (CD-AB)	.15"	.15"

(Solids not recommended for Mag Drive)

*With Max. Impeller Diameter

**With Standard Seal and Gasket. Please contact the factory for higher temperature and pressure options.

MATERIALS OF CONSTRUCTION-SEALED PUMP

PART	AI	BF	AB	SS
Volute	C.I.	C.I.	Bronze	316 SS
Bracket	C.I.	C.I.	Bronze	316 SS
Impeller	C.I.	Bronze	Bronze	316 SS
Fasteners	Plated Steel	Plated Steel	18-8SS	316 SS
Gasket	Syn. Fiber(CD100)	Syn. Fiber(CD100)	N/A	PTFE(CD100)
*O-ring	CD150	CD150	CD100/150	CD150
Shaft	316 SS	316 SS	316 SS	316 SS

* these models use an o-ring volute flange gasket. Material matches mechanical seal elastomer.
C.I. - Grey Cast Iron

MATERIALS OF CONSTRUCTION-MAG DRIVE

Volute	316 SS	"O" Ring	Fluoroelastomer
Bracket	316 SS	Bushings	Carbon
Shaft	316 SS	Thrust Washers	Carbon
Impeller	316 SS	Magnet Cup	316 SS
Fasteners	316 SS		

Type CD Mag Drive

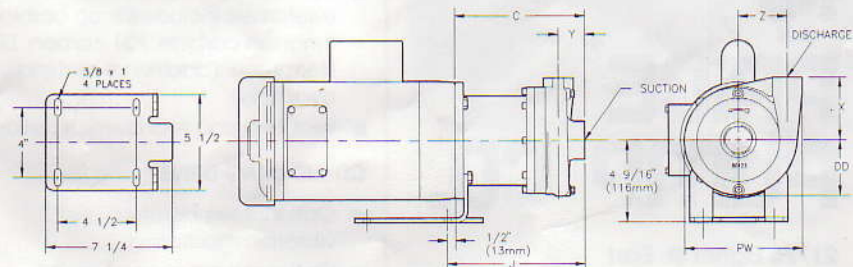

	PUMP END DIMENSIONS						PIPE THREADS IN INCH		
	C	DD	PW	X	Y	Z	J	SUCTION	DISCHARGE
CD100 SS MAG	7 3/8 187mm	3 1/8 79mm	7" 178mm	3 1/2 89mm	1 3/8 35mm	2 3/4 70mm	7 7/8 200mm	1 1/4" NPT	1" NPT
CD150 SS MAG	7 7/8 200mm	3 7/8 98mm	8 1/4 210mm	3 13/16 97mm	1 11/16 43mm	3 1/8 79mm	8 3/8 213mm	2" NPT	1 1/2" NPT